

iFIT Easy and fast to install



Easy and fast to install

iFIT is used for hot and cold water pipes in drinking water installations and for heating installations.

The rapid and easy jointing and dependable polybutene or multi-layer composite pipes render iFIT an extremely cost-effective choice.

Approved and tested.



iFIT Flow rate according to W3 D (2000)

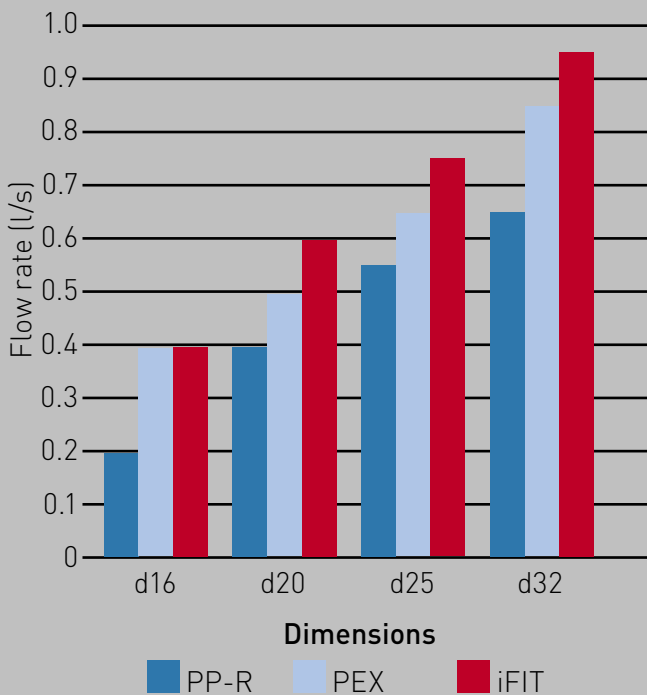

INSTAFLEX d16-d110

The universal complete system for the distribution of drinking water, including basement and riser pipes.

FIT d16-d32

The modular system for plumbing and heating. With 50% fewer components, more options compared to conventional installation systems.

Fewer parts, more options!

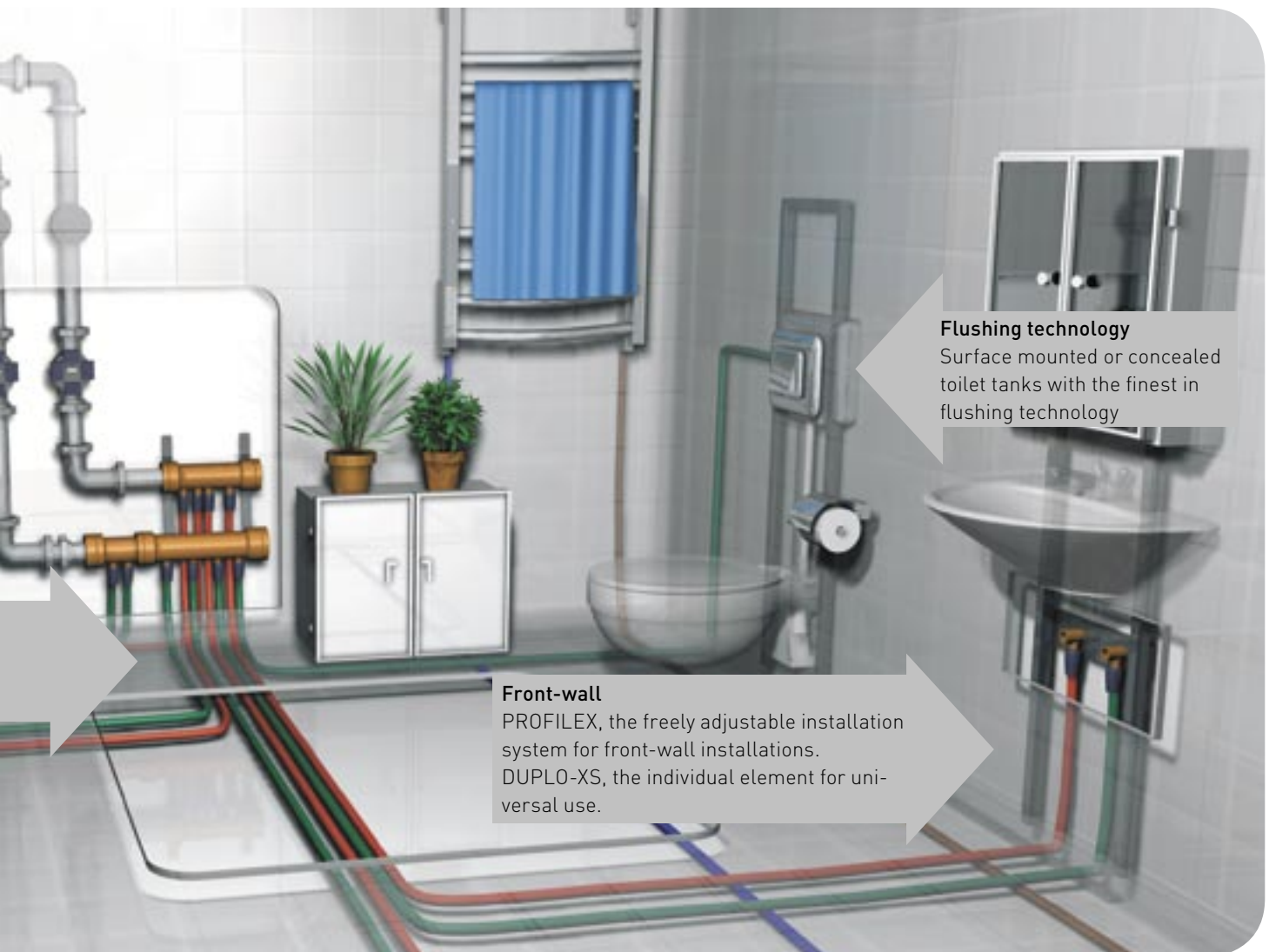

System concept



Set a new record

The modular iFIT system offers more options with 50% fewer components compared to conventional installation systems.

All you need on the job, safe and simply faster.



Technical Data

Pipe Material

- Non-permeable multi-layer composite pipes: aluminium core in between inner and outer plastic layers.
- Homogenous polybutene (PB) all-plastic pipes for plumbing installations.

Fittings material:

Fittings of state-of-the-art, high-performance PPSU plastic and dezincification-resistant brass.





Physical properties	Multi-layer composite	Polybutene
max. working temperature	95 °C / 5 bar	95 °C / 5 bar
max. continuous working pressure	10 bar / 70 °C	10 bar / 70 °C
Thermal conductivity (pipe)	0.43 W / mK	0.22 W / mK
Pipe surface roughness	0.007 mm	0.007 mm



Assembly instructions



1. Cut pipe square and to length with pipe shears or pipe cutter.

Important: iFIT tools must be used!



Important:
Cut pipe at 90° angle.



2. Calibrate and deburr pipe with hand tool. After 2-3 rotations, a circumferential bevel of at least 1 mm should be visible.



Important:
Following calibration, remove all shavings, inside and outside of the pipe.

Disassembly instructions

1. Open the body with two pliers (one plier on the collar, the other on the body) inner catch will snap off
2. Unscrew housing
3. Pull pipe out
4. Remove half-shells
5. Pull out nipple



Improper assembly or failing to follow the assembly instructions can result in leakage!



- 3.** Push the adapter onto the pipe until the stop. The correct insertion depth is visible in the window.



Important:
The adapters are individually packaged for protection. Only remove packaging immediately prior to use.



- 4.** Push the adapter onto the module until you hear it click into place.



Important:
The pipe is held in place with a dynamic mechanism that can cause it to move back a few mm during operation or the pressure test. In-wall adapters that are not insulated should be fit with insulation tape.

Disassembly tips:

- Every adapter may only be used once and must be destroyed after use!
- Caution: Risk of injury from sharp edges of retention ring!
- Correct installation always requires cutting the pipe to length!

Fastening technique

iFIT installations generally do not require any carriers or pipe supports.

Any commercially available fastening materials may be used for this purpose, taking into consideration the given spacing distances. For surface-mounted pipes, expansion must be absorbed either by changes in direction or expansion loops, according to the table on page 17

iFIT Fewer parts, more options!

Conventional system Tees 16/20/25/32

- Tee 16
- Tee 20
- Tee 20-16-20
- Tee 20-20-16
- Tee 20-16-16
- Tee 16-20-16
- Tee 25
- Tee 32
- Tee 32-25-32
- Tee 32-32-25
- Tee 32-25-25
- Tee 25-32-25



12 Tees

-50% system!

iFIT Tees 16/20/25/32

- T-module 16/20
- T-module 25/32
- Adapter 16
- Adapter 20
- Adapter 25
- Adapter 32



6 components

Diameter of protective sleeve for PB pipes

Conduit pipe d	Protective sleeve D
16	25
20	30
25	34

Installation guideline

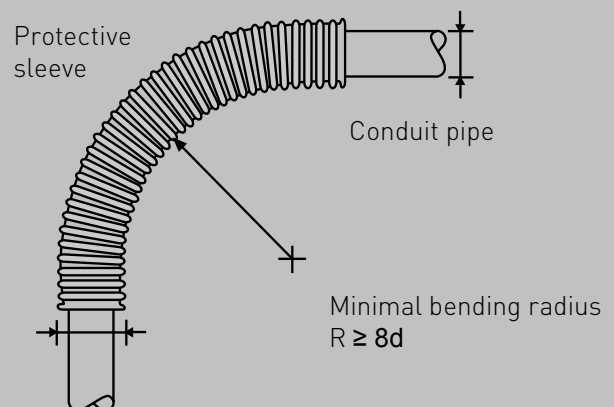

Unallowed system combinations

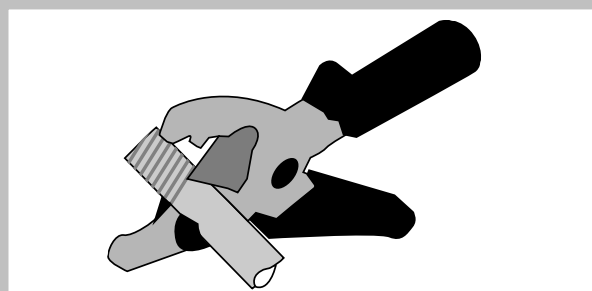
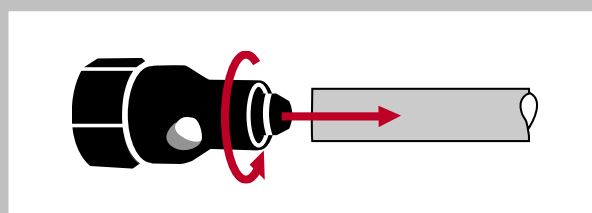
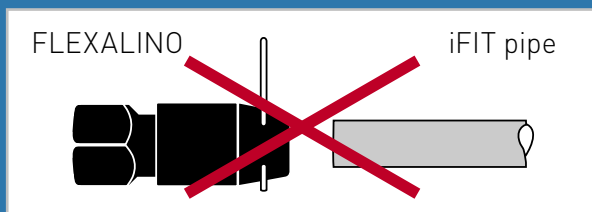
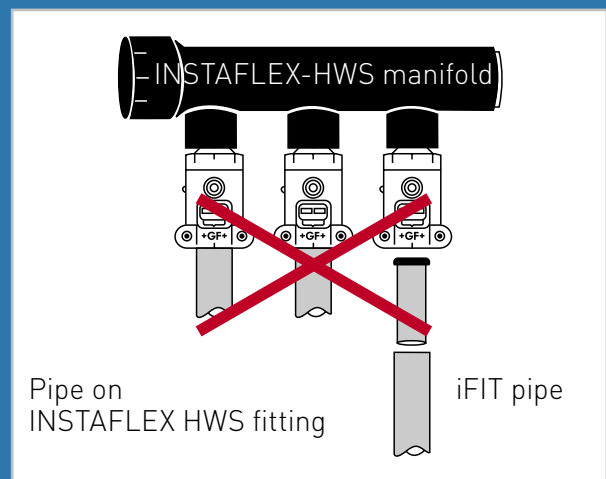
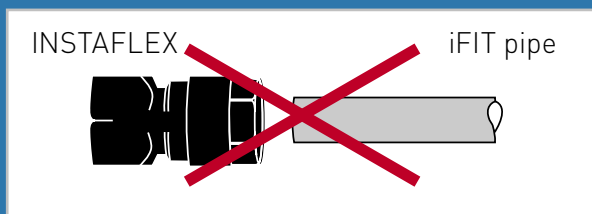
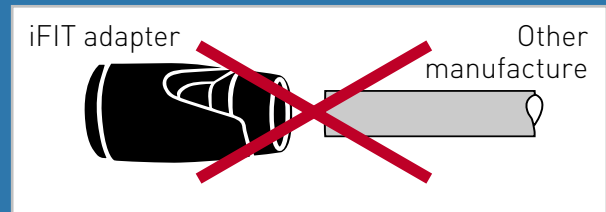
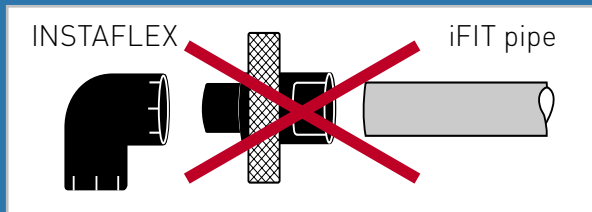

Application of the wall inlet plug for multi-layer composite and PB pipes

1. Fasten pipe until it's completely visible in the window
2. Remove wall inlet pipe after the pressure test
3. Cut damaged pipe before the installation

Connection values for valves and fixtures

Intended uses for 1/2" connectors	Flow rate l/s	per connection l/min	Load value number per connection
Wash basins, wash troughs, wash stands, bidets, toilet tanks, soft drink machines	0.1	6	1
Wash basins, sinks, taps for balcony and terrace, hairdresser hoses, home dishwashers, washing troughs	0.2	12	2
Showers	0.3	18	3
Industrial sinks, stand and wall basins, Bathtubs, washing machines up to 6 kg, automatic urinal flushing, kitchen spray nozzle	0.4	24	4
Taps for garden and garage	0.5	30	5
Intended uses for 3/4" connectors			
Industrial sinks, bathtubs, showers, Taps for industry and garden	0.8	48	8

Load value table for PB and multi-layer composite pipes

Total load values	3	4	5	13	25	55
Greatest single value			4	5	8	
$d_a \times s$ (mm)	16 x 2.0			20 x 2.0	25 x 2.5	32 x 3.0
d_i (mm)	12			16	20	26
Recommended pipe length in m	9	5	4			
Valve	1/2"			3/4"	3/4"	1"

Flushing times iFIT

Multi-layer composite pipe and PB pipe

Pipe d16 x 2.0		Water content per metre pipe 0.11 l			
Pipe length in metres	Flow in l/s	0.2	0.3	0.4	0.5
	Flushing time in seconds				
1	1.1	0.6	0.4	0.3	0.2
2	2.3	1.1	0.8	0.6	0.5
4	4.5	2.3	1.5	1.1	0.9
8	9.0	4.5	3.0	2.3	1.8
10	11.3	5.7	3.8	2.8	2.3
12	13.6	6.8	4.5	3.4	2.7
14	15.8	7.9	5.3	4.0	3.2
16	18.1	9.0	6.0	4.5	3.6

The technical data are not binding and are not expressly warranted characteristics of the goods. They are subject to change. Please consult our General Conditions of Supply.

Multi-layer composite pipe and PB pipe

Pipe d20 x 2.0		Water content per metre pipe 0.2 l			
Pipe length in metres	Flow in l/s	0.2	0.3	0.4	0.5
	Flushing time in seconds				
1	2.0	1.0	0.7	0.5	0.4
2	4.0	2.0	1.3	1.0	0.8
4	8.0	4.0	2.7	2.0	1.6
8	16.0	8.0	5.3	4.0	3.2
10	20.0	10.0	6.7	5.0	4.0
12	24.0	12.0	8.0	6.0	4.8
14	28.0	14.0	9.3	7.0	5.6
16	32.0	16.0	10.7	8.0	6.4

Pressure loss single tapping iFIT

(for multi-layer composite and PB pipe)

Table 2a: Pressure loss values Pipe d16 x 2.0/
manifold/valve connection/2 pipe bends

V in l/s	Loop length in metres					
	1	2	3	4	5	6
	Pressure loss of loop in mbar					
0.10	30	37	43	50	57	64
0.15	67	67	67	67	67	67
0.20	116	143	170	197	224	251
0.25	185	228	271	314	357	400
0.30	26	328	390	452	514	576
0.35	362	446	530	615	699	783
0.40	473	583	693	803	913	1023
0.45	599	738	878	1017	1156	-
0.50	739	911	1083	-	-	-

Table 2b: Pressure loss values Pipe d20 x 2.0/
manifold/valve connection/2 pipe bends

V in l/s	Loop length in metres					
	1	2	3	4	5	6
	Pressure loss of loop in mbar					
0.10	7	9	11	12	14	15
0.15	17	17	17	17	17	17
0.20	30	36	43	49	56	62
0.25	46	57	67	77	87	97
0.30	67	81	96	110	125	139
0.35	91	111	131	150	170	190
0.40	119	145	171	197	223	249
0.45	150	183	216	249	281	314
0.50	186	226	267	307	347	388
0.55	225	274	323	372	421	469
0.60	268	326	384	442	501	559
0.65	314	382	451	519	587	656
0.70	364	444	523	602	681	760
0.75	418	509	600	691	782	873
0.80	476	579	682	786	889	993

Multistory distribution

Piping systems and pressure loss calculation for multistory distribution.

Pressure loss which is a function of the flow in multistory distribution pipes is determined by using Tables 2a and 2b. Relevant for calculating the pressure loss is only the «hydraulic, least favourable flow path», i.e. the conduit with the greatest pressure loss.

The load values for valves and fixtures are contained in the table on page 10.

Individual feed pipes (loops)

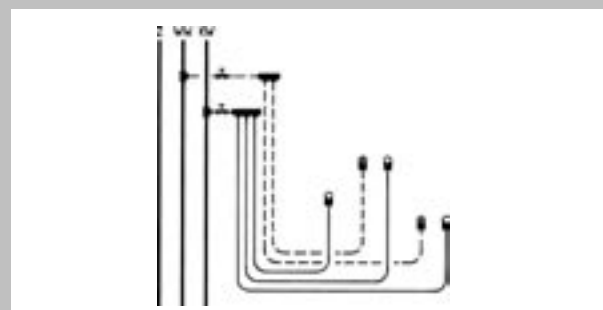

Individual feed pipes supply only one water tapping point apiece. The pressure loss can be read off the Tables 2a and 2b.

Continuous lines (loops)

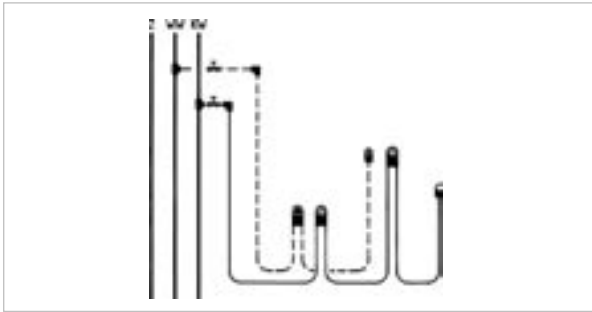

Continuous lines supply several water tapping points from the manifold. The serial connection of the tapping points requires adding up the pressure losses.

Assigning the valve with the largest load unit to the beginning of the line results in significantly less pressure loss than the opposite way around.

The pressure loss in continuous lines is calculated using the peak flow. The peak flow calculation allows for a reduced simultaneity, i.e. not all the tapping points on a flow path are

used at the same time and over the same time period.

The peak flow (l/s) is established with the help of the corresponding simultaneity diagrams or calculation formulas from the guidelines and the sum of the load units.

If the pressure loss does not permit connecting all the tapping points to one line, they are divided up into two or more lines.

Pressure losses in pipe loops

The pressure loss values from Table 2a and 2b contain individual resistances for changes in direction, valve connections and manifolds. The flushing time is calculated in relation to the fixtures (load values) on the entire length of the ring mains.

Ring mains

Ring mains supply several tapping points from the manifold. The tapping point is supplied with water from two sides.

Stagnation is thus avoided. In the ring mains there is ca. 70% less pressure loss compared to a continuous line.

To calculate the pressure loss, the ring mains is considered a continuous line with only one in-feed. The calculated pressure loss is multiplied by 0.3; the result is the pressure loss for the ring mains.

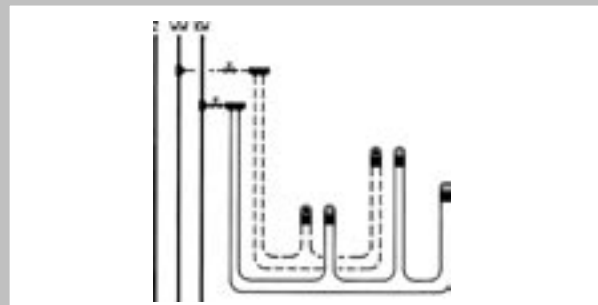

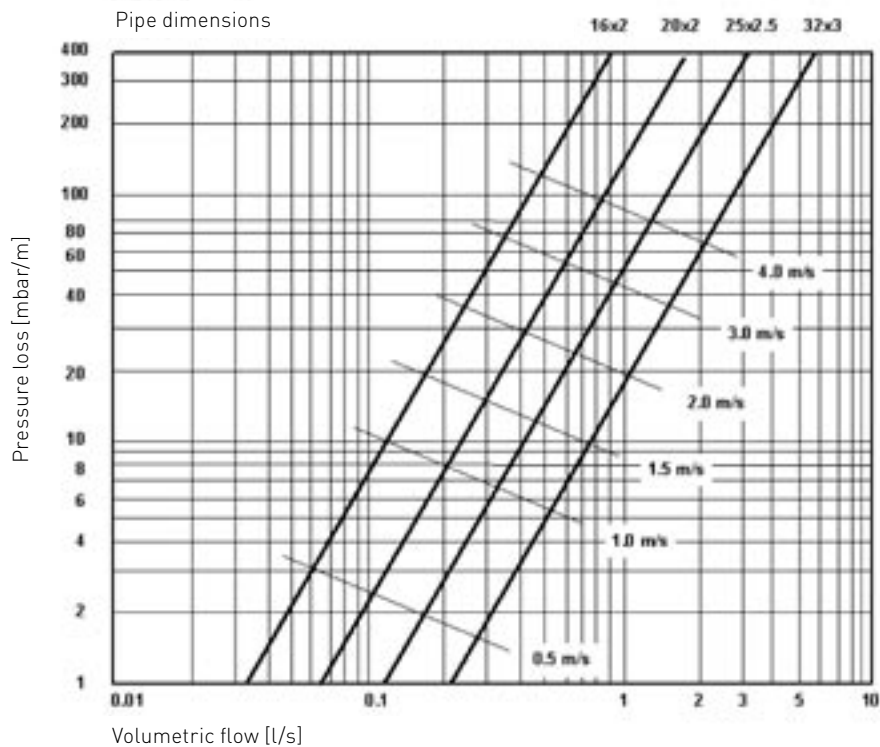

The dimensioning and planning of iFIT drinking water pipelines is based on the W3 Water Guidelines, the Technical Regulations for Drinking Water Installations, and Determining the Pipe Diameter.

Dimensioning of Drinking Water Pipes

(for multi-layer composite and PB pipe)

The data required for calculation is to be taken from the above diagram. The values listed below are calculated equivalent values.

Equivalent pipe lengths in metres

Dimension	d16 metres	d20 metres	d25 metres	d32 metres
T-channel	1.4	0.7	1.3	1.8
T-outlet	1.2	1.3	3.1	4.5
Elbow	1.6	1.3	1.9	1.8
Coupling	1.4	0.7	1.3	1.8
Valve connection single	1.4	1.7		
Valve connection double	1.0	1.7		
Manifold	1.6	1.7		

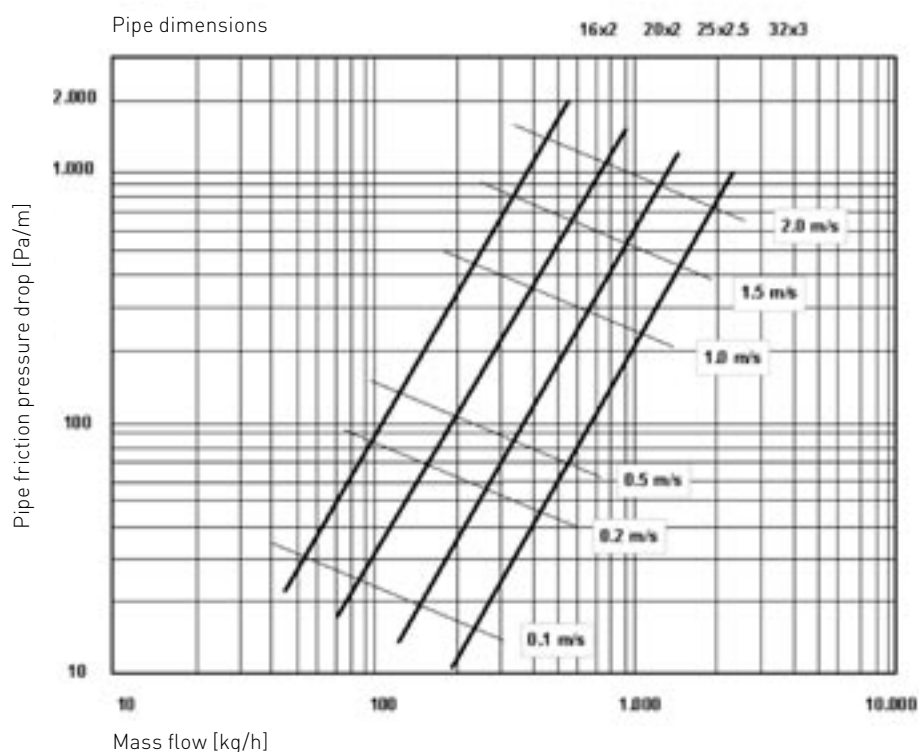

Pipe friction pressure drops in relation to mass flow at an average heating temperature of 60°C.

Dimensioning of Plumbing and Heating Pipes

(for multi-layer composite and PEX pipe)

The data required for calculation is to be taken from the above pressure loss diagram.

Zeta value (loss coefficient)

Dimension	d16 Zeta value	d20 Zeta value	d25 Zeta value	d32 Zeta value
T-channel	2.85	1.30	1.60	1.75
T-outlet	2.45	2.65	3.95	4.40
Elbow	3.25	2.65	2.35	1.75
Coupling	2.85	1.30	1.60	1.75
Valve connection single	2.85	3.30		
Valve connection double	2.05	3.30		
Manifold	3.25	3.30		

Bending radii for multi-layer composite pipes

The pipe is easily bent into the desired shape by means of an exterior bending spring.



Important: Do not use a bending spring on the inside! iFIT tools must be used!

Minimum bending radii with and without tools

Measurements Da x s mm	Bending radius by hand mm	Bending radius with Bending spring mm
16 x 2.0	5 x dA = 80	3 x dA = 48
20 x 2.0	5 x dA = 100	3 x dA = 60
25 x 2.5	8 x dA = 200	4 x dA = 100
32 x 3.0		4 x dA = 128

Bending radii for polybutene

Polybutene pipes can generally be laid with a bending radius of 8 x d.

Heat insulation

The general insulation specifications for plumbing and heating installations apply.

Fire protection measures

For pipes conducted through fire areas, please observe the guidelines of VKF (Swiss Assoc. of Cantonal Fire Insurances) and the MLAR (Model Pipeline Configuration Regulations).

iFIT pipes are in Fire Class B2 according to DIN 4102, Part 1.

Hygienically safe

The hygienic safety of iFIT pipes and fittings is warranted through annual inspections according to the KTW (Plastic Drinking Water Systems) guidelines of the Federal Health Agency and according to DVGW (German Technical and Scientific Assoc. on Gas and Water) worksheet W270.

Pipe bracket spacing

d in mm	RA in m
16	1.0
20	1.0
25	1.5
32	2.0

Expansion

Pipe length

Temperature difference

L in m	10 K in mm	20 K in mm	30 K in mm	40 K in mm	50 K in mm	60 K in mm	70 K in mm	80 K in mm
1.0	0.26	0.52	0.78	1.04	1.30	1.56	1.82	2.08
2.0	0.52	1.04	1.56	2.08	2.60	3.12	3.64	4.16
3.0	0.78	1.56	2.34	3.12	3.90	4.68	5.46	6.24
4.0	1.04	2.08	3.12	4.16	5.20	6.24	7.28	8.32
5.0	1.30	2.60	3.90	5.20	6.50	7.80	9.10	10.40
6.0	1.56	3.12	4.68	6.24	7.80	9.36	10.92	12.48
7.0	1.82	3.64	5.46	7.28	9.10	10.92	12.74	14.56
8.0	2.08	4.16	6.24	8.32	10.40	12.48	14.56	16.64
9.0	2.34	4.68	7.02	9.36	11.70	14.04	16.38	18.72
10.0	2.60	5.20	7.80	10.40	13.00	15.60	18.20	20.80
15.0	3.90	7.80	11.70	15.60	19.50	23.40	27.30	31.20
20.0	5.20	10.40	15.60	20.80	26.00	31.20	36.40	41.60

Expansion bends

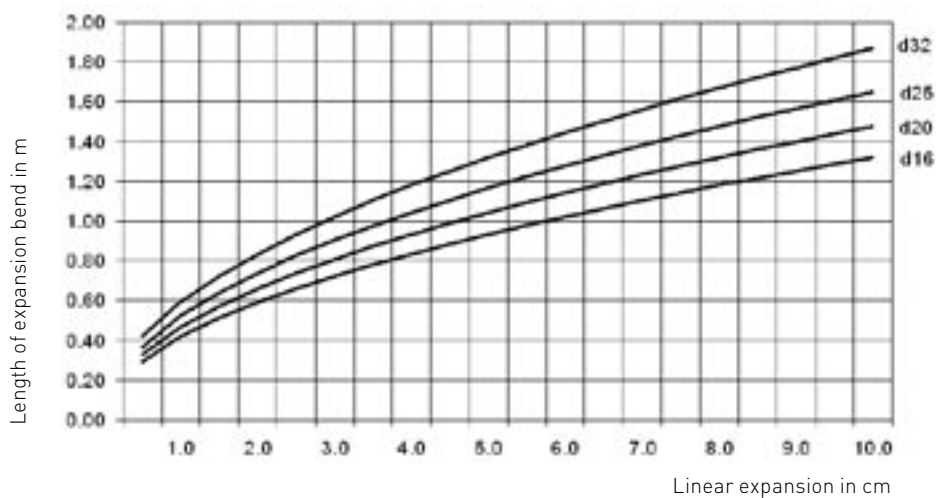



Calculation example

Dimension	M-M	h [T 90]	z [Adapter 1]	z [Adapter 2]	h Elbow 90°	Pipe size L [mm]
d 16	500	31	4.5	4.5	36	424
d 20	500	31	4.5	4.5	36	424
d 25	500	45	7.5	7.5	54	386
d 32	500	45	7.5	7.5	54	386

**Tee equal
Position change Elbow 45° Pipe bends**

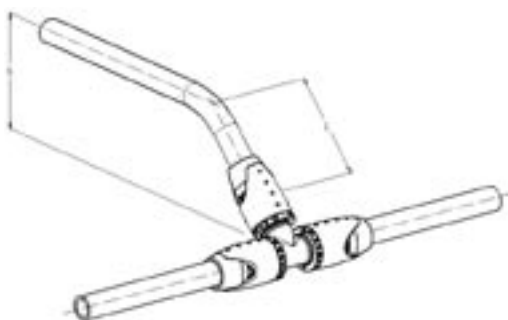

Position change	Dim DN	16	20	25	32
h min	mm	65	85	105	160
h mm	M-M mm	Pipe size L			
		mm	mm	mm	mm
80	113	71	-	-	-
90	127	85	85	-	-
100	141	100	100	-	-
110	156	114	114	-	-
120	170	128	128	108	-
130	184	142	142	122	-
140	198	156	156	136	-
150	212	170	170	150	-
160	226	184	184	164	164
170	240	199	199	178	178
180	255	213	213	193	193
190	269	227	227	207	207
200	283	241	241	221	221
210	297	255	255	235	235
220	311	269	269	249	249

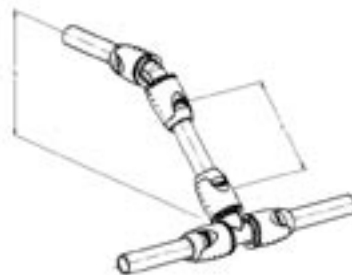
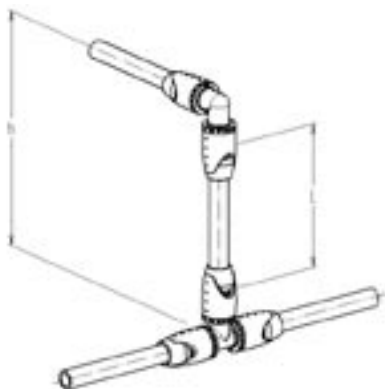

Tee equal

Position change Elbow 90° Module

Position change	Dim	16	20	25	32
h min	DN	12	16	20	26
h mm	mm	210	210	250	250
h mm	M-M mm	Pipe size L			
		mm	mm	mm	mm
210	210	127	127	-	-
220	220	137	137	-	-
230	230	147	147	-	-
240	240	157	157	-	-
250	250	167	167	126	126
260	260	177	177	136	136
270	270	187	187	146	146
280	280	197	197	156	156
290	290	207	207	166	166
300	300	217	217	176	176
310	310	227	227	186	186
320	320	237	237	196	196
330	330	247	247	206	206
340	340	257	257	216	216
350	350	267	267	226	226

Position change Elbow 45° Module

Position change	Dim	25	32
h min	DN	20	26
h mm	mm	170	170
h mm	M-M mm	Pipe size L	
		mm	mm
170	240	130	130
180	255	145	145
190	269	159	159
200	283	173	173
210	297	187	187
220	311	201	201
230	325	215	215
240	339	229	229
250	354	244	244
260	368	258	258
270	382	272	272
280	396	286	286
290	410	300	300
300	424	314	314
310	438	328	328

GF Piping Systems → worldwide

Our sales companies and representatives ensure local customer support in over 100 countries.

www.piping.georgfischer.com



The technical data are not binding and not expressly warranted characteristics of the goods. They are subject to change. Our General Conditions of Sale apply.

Australia

George Fischer Pty Ltd
Kingsgrove NSW 2008
Phone +61(0)2/95 54 39 77
sales@georgfischer.com.au
www.georgfischer.com.au

Austria

George Fischer
Rohrleitungssysteme GmbH
3130 Herzogenburg
Phone +43(0)2782/856 43-0
office@georgfischer.at
www.georgfischer.at

Belgium/Luxembourg

George Fischer NV/SA
1070 Bruxelles/Brüssel
Phone +32(0)2/556 40 20
info.be@be.piping.georgfischer.com
www.georgfischer.be

Brazil

George Fischer Ltda
04795-100 São Paulo
Phone +55(0)11/5687 1311

China

George Fischer Piping Systems Ltd Shanghai
Pudong, Shanghai 201319
Phone +86(0)21/58 13 33 33
info@cn.piping.georgfischer.com
www.cn.piping.georgfischer.com

Denmark/Iceland

Georg Fischer A/S
2630 Taastrup
Phone +45 (0)70 22 19 75
info@dk.piping.georgfischer.com
www.georgfischer.dk

France

Georg Fischer S.A.S.
93208 Saint-Denis Cedex 1
Phone +33(0)1/492 21 34 1
info@georgfischer.fr
www.georgfischer.fr

Germany

George Fischer GmbH
73095 Albershausen
Phone +49(0)7161/302-0
info@georgfischer.de
www.rls.georgfischer.de

George Fischer DEKA GmbH

35232 Dautphetal-Mornshausen
Phone +49(0)6468/915-0
info@dekapipe.de
www.dekapipe.de

Greece

Georg Fischer S.p.A.
10434 Athens
Phone +30(0)11/882 04 91
office@piping-georgfischer.gr

India

George Fischer Piping Systems Ltd
400 093 Mumbai
Phone +91(0)22/2820 2362
branchoffice@georgfischer.net

Italy

Georg Fischer S.p.A.
20063 Cernusco S/N (MI)
Phone +3902/921 861
office@piping.georgfischer.it
www.georgfischer.it

Japan

George Fischer Ltd
556-0011 Osaka,
Phone +81(0)6/6635 2691
info@georgfischer.jp
www.georgfischer.jp

Malaysia

George Fischer (M) Sdn. Bhd.
47500 Subang Jaya
Phone +60 (0)3-8024 7879
conne.kong@georgfischer.com.my

Netherlands

Georg Fischer N.V.
8161 PA Epe
Phone +31(0)578/678 222
info.vgnl@nl.piping.georgfischer.com
www.georgfischer.nl

Norway

Georg Fischer AS
1351 Rud
Phone +47(0)67 18 29 00
info@no.piping.georgfischer.com
www.georgfischer.no

Poland

Georg Fischer Sp. z o.o.
02-226 Warszawa
Phone +48(0)22/313 10 50
www.georgfischer.pl

Romania

George Fischer
Rohrleitungssysteme AG
70000 Bucharest - Sector 1
Phone +40(0)1/222 91 36
office@georgfischer.ro

Singapore

George Fischer Pte Ltd
417 845 Singapore
Phone +65(0)67 47 06 11
info@georgfischer.com.sg
www.georgfischer.com.sg

Spain/Portugal

Georg Fischer S.A.
28009 Madrid
Phone +34(0)91/781 98 90
info@georgfischer.es
www.georgfischer.es

Sweden/Finland

Georg Fischer AB
12523 Älvsjö-Stockholm
Phone +46(0)8/506 775 00
info@georgfischer.se
www.georgfischer.se

Switzerland

Georg Fischer Rohrleitungssysteme (Schweiz) AG
8201 Schaffhausen
Phone +41(0)52 631 30 26
info@rohrleitungssysteme.georgfischer.ch
www.piping.georgfischer.ch

United Kingdom/Ireland

George Fischer Sales Limited
Coventry, CV2 2ST
Phone +44(0)2476 535 535
info@georgfischer.co.uk
www.georgfischer.co.uk

USA/Canada/Latin America/Carribbean

George Fischer Inc.
Tustin, CA 92780-7258
Phone +1(714) 731 88 00, Toll Free 800/854 40 90
info@us.piping.georgfischer.com
www.us.piping.georgfischer.com

Export

Georg Fischer Rohrleitungssysteme (Schweiz) AG
8201 Schaffhausen
Phone +41(0)52 631 11 11
export@piping.georgfischer.com
www.piping.georgfischer.com

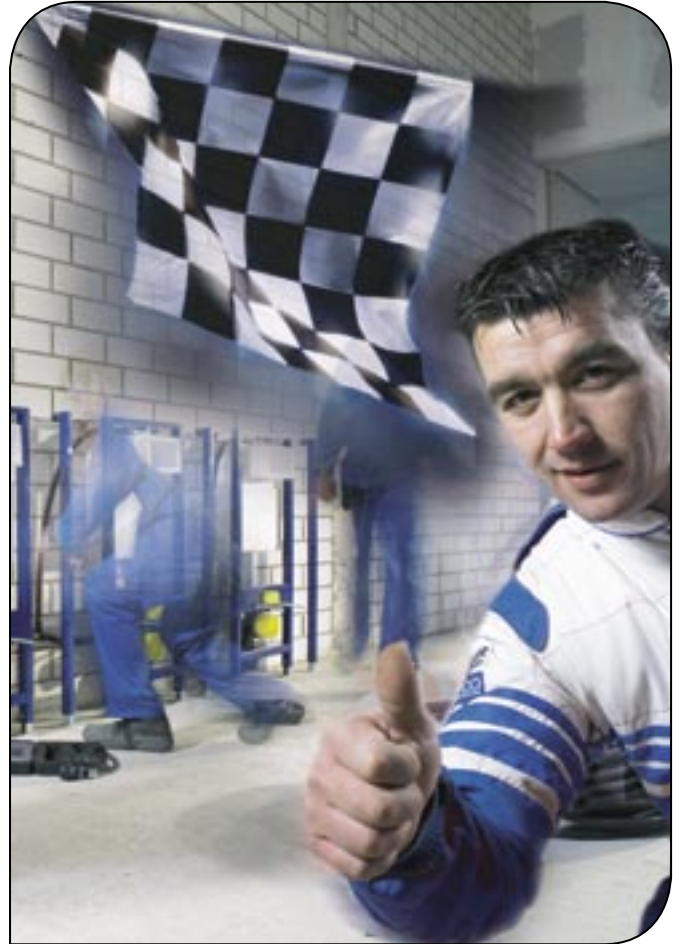

Technical Data 2005

The new and faster
installation system for
plumbing and heating

iFIT

simply **faster** to install