

SIMPLEX STRAINER MODEL 90

The Eaton Model 90 Fabricated Simplex Strainer has been designed for manufacturing flexibility. It can be made for pipeline sizes from 1" to 48" in carbon steel or stainless steel although other materials can be specified. Three different ratings of flange connections are commonly available: ANSI Class 150, 300, and 600. Higher pressures are also available. The strainer features an in-line design that adapts to most applications.

Two different types of covers are available. The simplest type is the bolted cover which is simple and cost effective and works well in applications where basket changing is infrequent. A davit assembly can also be specified for larger strainers with heavy covers. This makes it possible for a single person to remove the cover of the strainer.

If the strainer will be opened frequently for basket cleaning, a bolted cover can be less effective because of the time needed to remove and then tighten the bolts. For these applications The Eaton Model 90 Strainer can be ordered with a special, hinged, quick opening cover that is secured by swing bolts. This type of quick opening cover can even be adapted for higher

pressure applications. For medium size strainers, 8" to 16", a bolted slide hinge cover is available. This permits a single operator to open the cover. Eaton strainers can also be designed and manufactured with special covers to meet any application requirements.

There is a special, unique Eaton strainer basket for the Model 90 Fabricated Strainer. The basket has a slant top design which improves the flow through the strainer and results in significantly lower pressure drops than would otherwise be the case. The slant top design results in a more compact basket which weighs less than an ordinary basket and makes it possible for a single person to remove it from the strainer housing. A real labor saving feature when it becomes time to clean or change out the basket. Strainer baskets for the Model 90 are made of stainless steel, although almost any type of material can be specified. Basket perforations from 1/32" up to 1" are available and mesh linings in sizes from 20 to 400 mesh for fine straining applications can be specified.

The Model 90 Fabricated Simplex Strainer will meet the requirements of most simplex strainer applications. It is



8" Model 90 carbon steel with bolted cover.

Basket & Screen Effective Area

Strainer Model	Pipe Size in.	Perforation Size - in.	Nominal Area of Pipe (sq in)	Gross Screen Area (sq in)	Free Area (sq in)	Ratio Free Area to Pipe Area
90	2	5/32	3.35	78	49	14.60
90	3	5/32	7.39	94	59	8.00
90	4	5/32	12.73	151	95	7.46
90	5	5/32	20.00	204	128	6.40
90	6	5/32	28.90	283	178	6.16
90	8	5/32	50.02	478	301	6.02
90	10	5/32	78.85	691	435	5.52
90	12	5/32	111.93	942	593	5.30
90	14	5/32	135.28	1320	832	6.15
90	16	5/32	176.71	1659	1045	5.91
90	18	5/32	223.68	1979	1247	5.57
90	20	5/32	277.95	2513	1583	5.70
90	24*	5/32	402.00	4071	2565	6.38

*Contact Eaton for larger sizes. Dimensions are for reference only.

SIMPLEX STRAINER MODEL 90



Special Model 90 strainer with offset nozzles, quick open cover, and flanged drain

also easy to customize the strainer to meet special application requirements.

Some common, easy-to-fabricate modifications are rotated nozzles, offset nozzles, and horizontal-vertical flow. Rotated inlet and outlet nozzles such as a right angle design can eliminate the requirement for an elbow in the downstream piping. Offset nozzles, lowering or raising either the inlet or outlet nozzle, can often eliminate serious alignment and support problems. The horizontal-vertical design with the flow exiting the strainer at a 90 degree angle can simplify the installation of a strainer in an already existing piping system.

Fabricated simplex strainers can also be designed with a backflush/backwash option. In these designs a piping connection with an on/off backflush valve is fabricated at the strainer bottom and has a connection to the bottom of the strainer basket. When solids accumulate in the bottom of the basket, the backflush valve is opened and the differential pressure between the operating pressure and the backflush system removes the solids without shutting the system down. Backflushing is often supplemented by a back washing operation.

Backwashing is done by having fluid flow, under pressure, in the reverse direction into an empty strainer. This flow reversal backwashes the basket and removes the residual dirt. Backwashing is often regarded as a second step, used to remove dirt not removed by backflushing.

Steam jacketing is another option available for fabricated strainers. Steam jacketing is used to maintain critical fluid temperatures through the strainer. High temperatures are often required to process and transport highly viscous fluids. This modification is designed so that there is no impact on the function or normal maintenance of the strainer. Steam jacketing is available in carbon steel and type 316 stainless steel for service up to 450°F.

Eaton Model 90 strainers can be designed and fabricated to ASME section VIII and ANSI B31.1, .3, .4, .7, and .8 codes. Welders are qualified to ASME Sec. IX.

Contact us today to discuss your special fabricated simplex strainer requirements.



24" Model 90 low profile carbon steel fabricated strainer

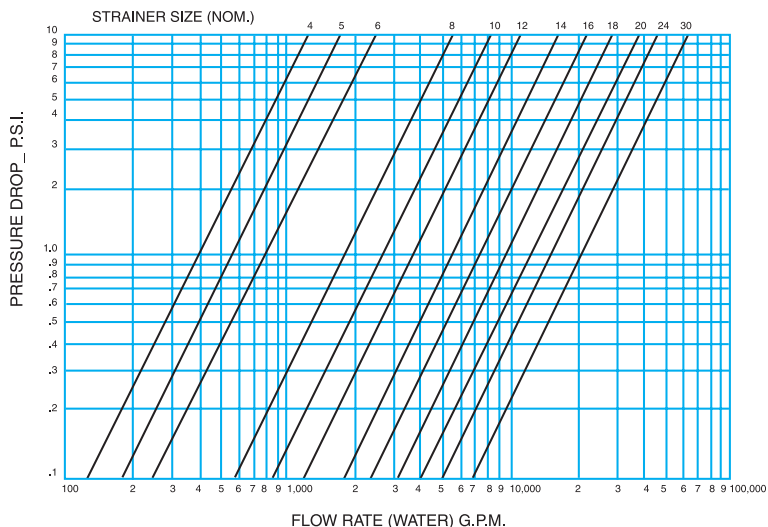

SIMPLEX STRAINER MODEL 90

- Sizes from 4" to 24" - As Standard
- Available in Carbon Steel - Stainless Steel*
- Flanged ANSI Class 150 and 300 - As Standard
- Flanged Class 600 and higher - Available on request

*SSTL strainers include carbon steel, external non-wetted fasteners as standard

- Two cover types available: quick opening hinged & bolted blind
- Davit assembly optional
- Basket material: stainless steel, 1/32" to 1/2" perforation diameter. 20 to 400 mesh linings also available.

Bolted Cover

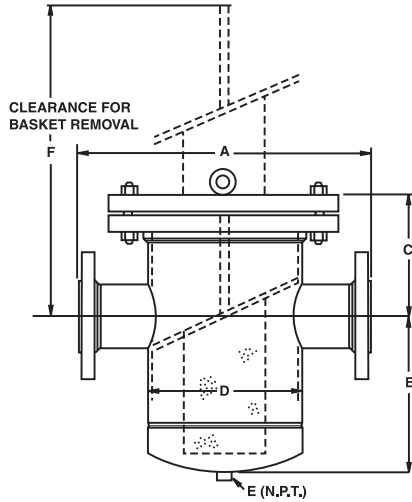

Nom Size	Dimensions								Net Weight (lb)			
	A		B	C		D	E	F	Class 150		Class 300	
	Class 150	Class 300		Class 150	Class 300				Cover	Unit	Cover	Unit
4	16	16	14	8½	9½	8¾	1	21	45	147	81	219
5	16	17½	15	9½	11	10¾	1	22	45	153	81	237
6	20	21	17	9½	11	10¾	1	24	70	203	127	328
8	22	23	21	11	12½	12¾	1½	28	110	281	184	407
10	32	33	25	13	14½	16	1½	33	170	450	307	710
12	35	36	28	14½	16	18	1½	39	209	644	390	1024
14	37	38	33	15¾	17½	20	2	45	272	951	492	1397
16	42	43	36	18¼	20	24	2	49	411	1409	754	2011
18	42	43	39	18¼	20	24	2	53	411	1486	754	2127
20	43	44½	44	21¾	24	30	2	59	411	1553	754	2231
24	48	49¾	60	21¾	24	30	2	78	681	2291	1403	3497

Dimensions are in inches

These dimensions are for reference only. For installation purposes, request certified drawings.

Quick-Opening Hinged Cover

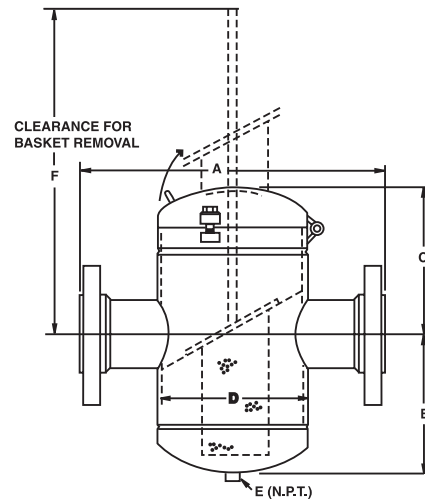

Nom Size	Dimensions							Net Weight (lb)			
	A		B	C	D	E	F	Class 150		Class 300	
	Class 150	Class 300		Class 150/300				Cover**	Unit	Cover**	Unit
4	16	16	14	9½	8¾	1	21	9	122	9	158
5	16	17½	15	11¼	10¾	1	22	9	128	9	176
6	20	21	17	11¼	10¾	1	24	12	168	12	236
8	22	23	21	13	12¾	1½	28	15	226	15	278
10	32	33	25	15¾	16	1½	33	30	360	30	483
12	35	36	28	17¾	18	1½	39	37	535	37	734
14	37	38	33	19¾	20	2	45	46	804	46	1030
16	42	43	36	23¼	24	2	49	68	1188	68	1437
18	42	43	39	23¼	24	2	53	68	1255	68	1553
20	43	44½	44	27¾	30	2	59	71	1322	71	1656
24	48	49¾	60	27¾	30	2	78	88	1860	88	2344

Dimensions are in inches

** Force required to lift cover in lb.

These dimensions are for reference only. For installation purposes, request certified drawings.

Contact Eaton for larger sizes.

SIMPLEX STRAINER MODEL 90

COVER OPENING OPTIONS:

Maintenance problems can result if proper consideration is not given to the process involved in removing and replacing strainer access covers. This is particularly true in sizes larger than 8" where the cover weight can easily exceed 150 pounds, in which case additional personnel and equipment may be required. The Eaton designs listed below were developed to eliminate the problems associated with this process.

Standard Hinged

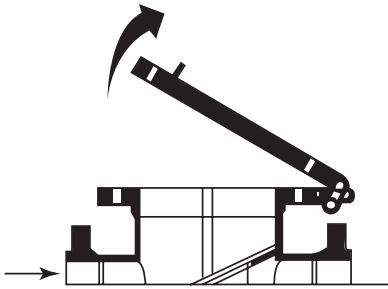

The quick opening hinged cover is available on most fabricated strainers. It has the added advantage of swing bolts, and is particularly helpful if the access is on the vertical or bottom.

Integral Davit

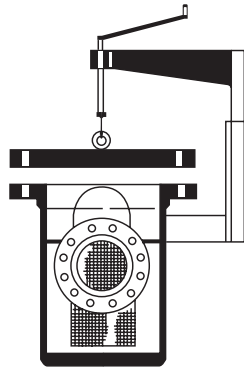

The cover lift davit can reduce any cover lift process to a one man operation.

Bolted Slide Hinge

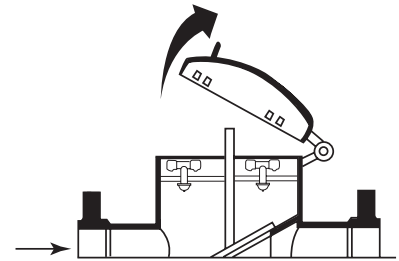

The slide hinge in medium size ranges (8"-16") permits a single operator to engage the hinge and open the cover.

NOZZLE PLACEMENT OPTIONS:

Fabricated strainers are available with a multitude of nozzle design options to adapt them to existing or contemplated piping schemes.

Rotated Nozzles

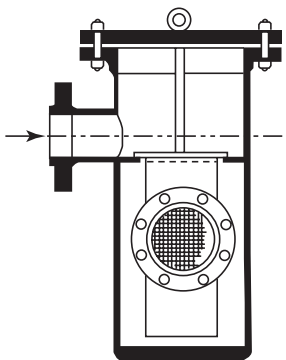

Right angle design can eliminate the requirement for an elbow in the downstream piping.

Offset Nozzle

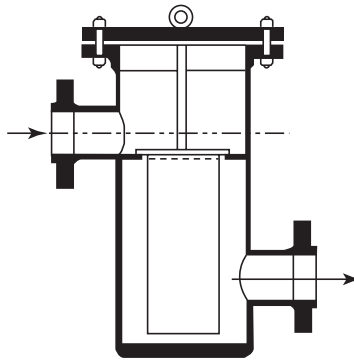

By lowering or raising either nozzle, serious alignment and support problems can be avoided.

Horizontal-Vertical

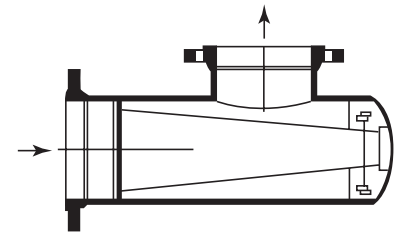

The above right angle design is especially appropriate for existing piping, and is typical of the many modifications that are possible.

OPTIONS

BACKFLUSH/BACKWASH OPTION:

Custom fabricated simplex and duplex strainers are available with this important option.

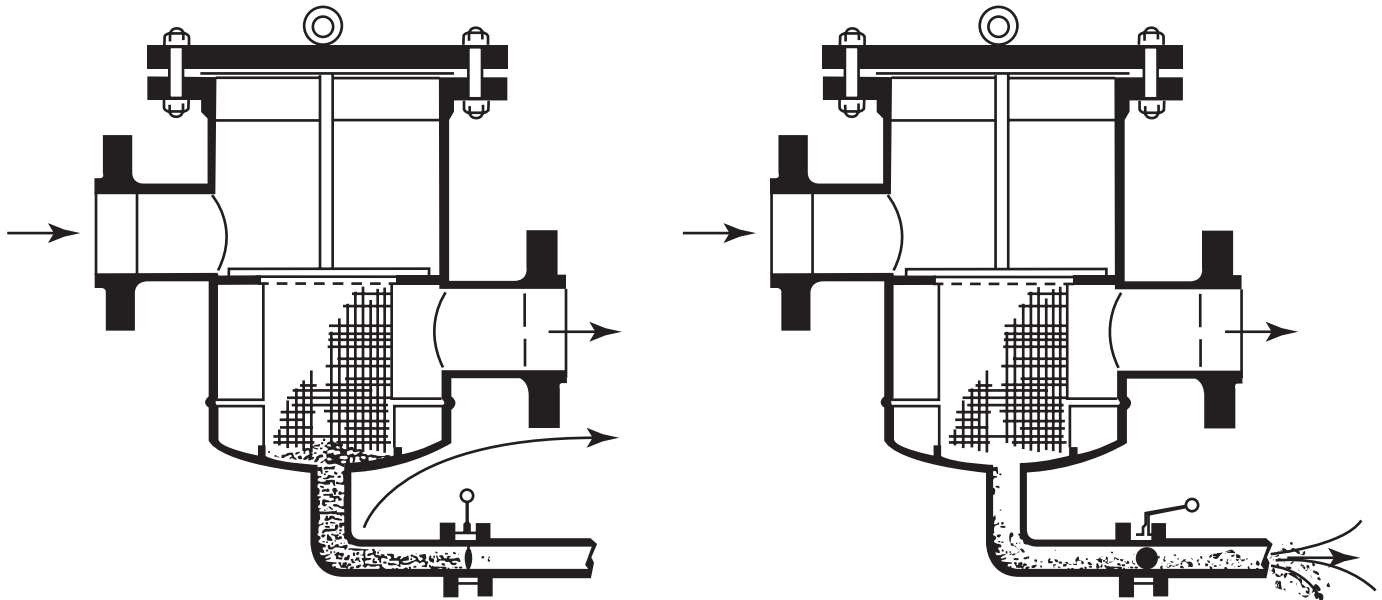

(A) Valve closed - dirt accumulated

(B) Valve open - dirt removed thru backwash piping.

In many systems, particularly where solids are heavy and well defined, dirt accumulates as shown above (A). When the backflush valve is open, (B), the differential pressure between the operating pressure and the backflush system removes the dirt, all without shutting the system down. This simple process is referred to as backflushing.

Backwashing occurs when backflushing is supplemented by fluid flowing, under pressure, in the reverse direction into an empty strainer. This flow reversal backwashes the element and removes the residual dirt. Backwashing is often regarded as a second step, used to remove dirt not removed by backflushing.

STEAM JACKET OPTION:

Custom fabricated simplex basket and tee strainers in all sizes are also available with this option. This modification is designed to have no impact on the function or normal maintenance.

Steam jacketing is available in carbon steel and 316SS for service up to 450°F. Steam jacketing is used to maintain critical fluid temperatures through the strainer. High temperatures are often required to process and transport high viscous fluids.