

# TECHNICAL INFORMATION

## HOW TO MEASURE A VALVE

In order to supply correct valve we want information about dimensions acc to below.  
If possible also medium, pressure and temperature

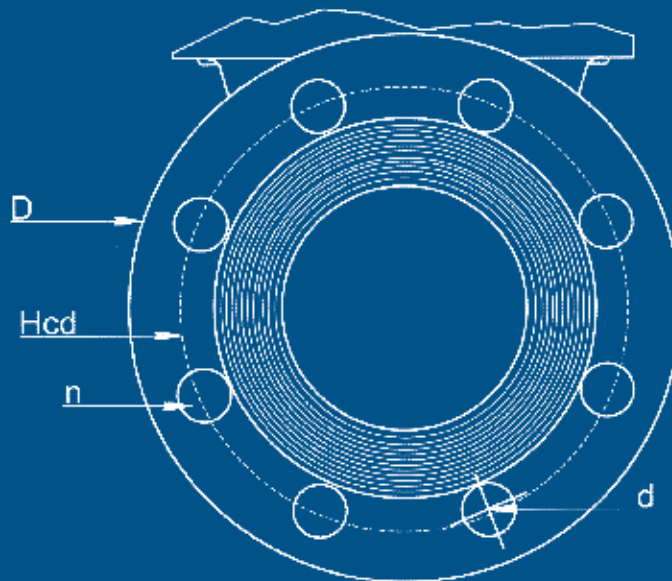
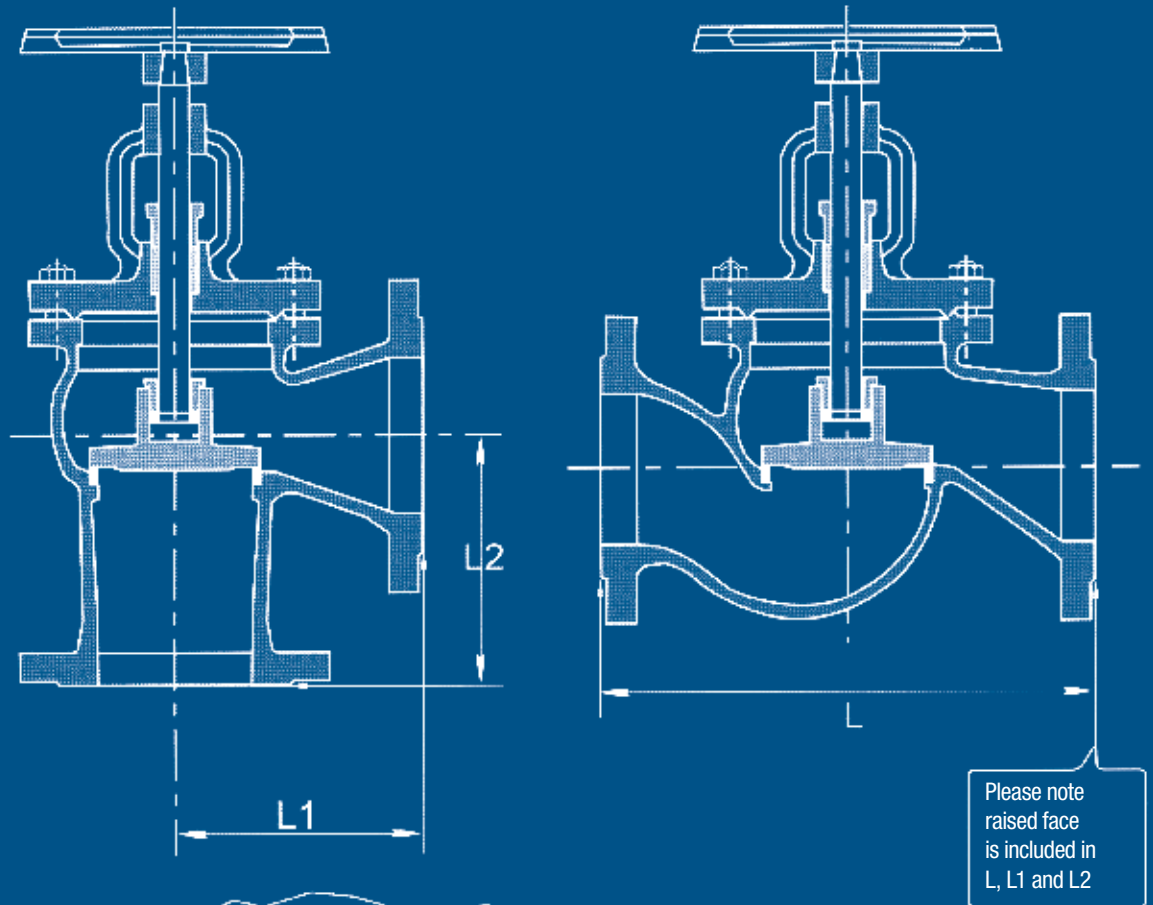

### TECHNICAL FEATURES

- L = Face to face length
- L1 = Face to center length
- L2 = Face to center length
- D = Flange diameter
- n = Number of bolt holes
- Pcd = Pit circle diameter
- d = Diameter of bolt holes