

TECHNICAL DATA

MUD BOX (BASKET STRAINER)

STRAIGHT TYPE

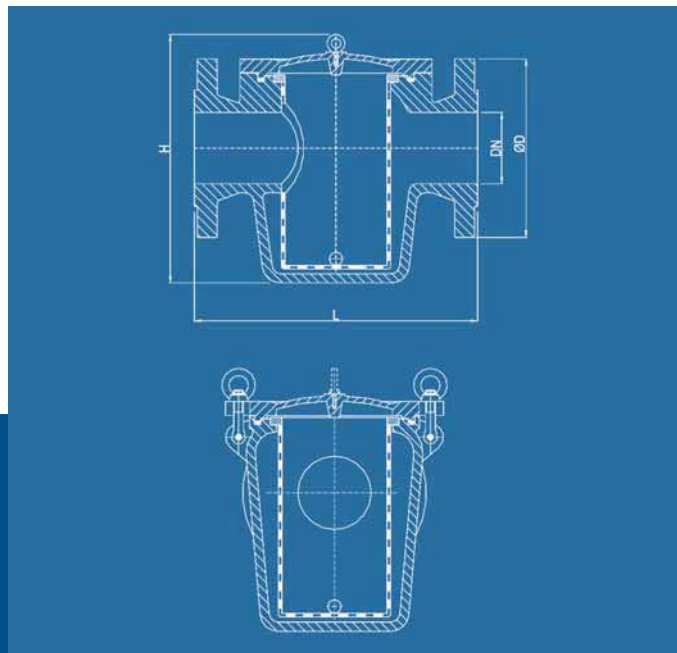

DIMENSIONS

DN (mm)	Pressure rating	ØD PN10	ØD PN16	L (mm)	H (mm)	Weight (kg)
25	PN 4	115	115	160	180	6.0
32	PN 4	140	140	200	210	10
40	PN 4	150	150	200	210	12
50	PN 4	165	165	230	225	12
65	PN 4	185	185	290	265	23
80	PN 4	200	200	310	300	28
100	PN 4	220	220	350	340	39
125	PN 4	250	250	400	415	63
150	PN 4	285	285	480	465	84
175	PN 4	315	315	600	575	141
200	PN 4	340	340	600	575	155
250	PN 4	395	405	600	620	175
300	PN 4	445	460	600/700*	660	235
350	PN 4	505	520	610/690/800*	740	300
400	PN 4	565	580	740	900	430
450	PN 4	615	640	1000	1000	480
500	PN 2.5	670	715	1100	1100	555
600	PN 2.5	780	840	1100	1100	820
700	PN 2.5	895	910	1250	1150	1000
750	PN 2.5	965	975	1350	1200	1200

*STANDARD LENGTH



TECHNICAL FEATURES

Body	Cast iron / Ductile iron
Gasket	Stainless steel
Design	DIN 87151 D - with fixed studs and nuts
Face to Face	DIN 87151 - Straight Type
Flange Dimension	DIN Flanges acc. to EN 1092/B (DIN 2501)
Pressure Rating	PN 2.5 / PN 4
Temperature Range	-10 °C...+120 °C
Options	Brass bow nuts, CuNiFe basket or special perforation, air plug or air vent valve on the cover
Flange Options	Special flange drilling acc. to ANSI or JIS

- Mud boxes with DIN face to face length and drain plug are installed in suction pipes board vessels to protect pumps against large solids.
- The standart perforation of the basket is 5 mm square for DN 25 to DN 65, and 8 mm square for DN 80 to DN 750. As an option basket perforation can be 3 mm or other special perforation. The cover is mounted with wing bolts and eye nuts.
- Application: Especially for suction and discharge lines for sea cooling water and bilge systems.

www.wosupply.com